

Development of Experimental Target Platforms for Rayleigh-Taylor and Jetting Experiments at LLE

J. Robinson, C. Spindloe

Scitech Precision Limited,
Rutherford Appleton Laboratory, Harwell Campus, Didcot,
Oxon, OX11 0QX, UK

S. Klein, J. Schnell

Nuclear Engineering & Radiological Sciences, University of
Michigan, Ann Arbor, MI 48109, USA

Introduction

This report looks at the development of two examples of targets that Scitech Precision were tasked with delivering for high power laser experiments at The University of Rochester's Laboratory for Laser Energetics (LLE). LLE hosts the Omega laser facility and the Omega laser [1] where the following targets were fielded over a period of 2 years. Working closely with the target fabrication group in the Central Laser Facility (CLF) and the target fabrication team at the University of Michigan, Scitech Precision were able to bring together expanded capabilities and technologies to fabricate ever increasing complex targets and to characterise them in the high detail required to benchmark them for the experimental campaigns. These capabilities include manufacturing of modulated brominated plastics by using single point diamond turning to produce the structures, production of low-density foams integrated into the target package, laser micromachining, micro assembly, and additive manufacturing (3D printing) of components. The latter permits high precision printing of microscale components since the addition of a 10um BMF S240 printer [2]. Characterisation was carried out using X-Ray CT and radiography.

A. Modulated Brominated Plastic Targets

These targets were designed for instability studies where the driven target plasma is imaged using x-rays to study its evolution [3]. In this design a modulated pusher is irradiated, and the plasma flows into a low-density foam material. Previous designs of the modulated brominated plastic (CHBr) target included a coated plastic ablator (10um thick Parylene-N) with an Aluminium (Al) flash coating on the laser drive side and a 1um gold (Au) coating to the rear. A copper (Cu) pinhole was then glued to the Au coated side to act as a shield for the central modulated interface to stop the plasma from the interaction being visible in the transverse x-ray probe [4]. The CHBr modulated interfaces (mono- and bi-mode) were 40um thick. A range of low-density foams (20 mg/cc – 200mg/cc) were manufactured within a Polyimide (PI) tube (1.8mm Dia, 1.5mm long) with a PI cap to help contain the foam. The foam was then assembled directly onto the modulated interface (Figure 1).

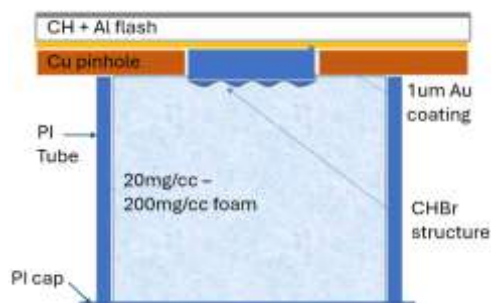

Figure 1 – Schematic of the initial target design.

S. Irving, D. Wyatt, C. Dobson, M. Harris, P. Ariyathilaka

Central Laser Facility, UKRI-STFC, Rutherford Appleton
Laboratory, Harwell Campus, Didcot, Oxon, OX11 0QX, UK

P. M. Nilson

Laboratory for Laser Energetics (LLE), University of
Rochester, 250 E River Rd, Rochester, NY 14623, USA

Modulated structures

For the modulated structures, a brominated CH powder was heat pressed onto a diamond turned Cu block with the necessary wave profiles. The CHBr was removed from the Cu block using IPA and laser micromachined to the required size. The depth and profile of the modulated structures were checked using a surface profilometer (Bruker DektakXT) to measure the surface of the Cu parts prior to the CHBr pressing (Figure 2). This showed the wave profiles were as require for the targets.

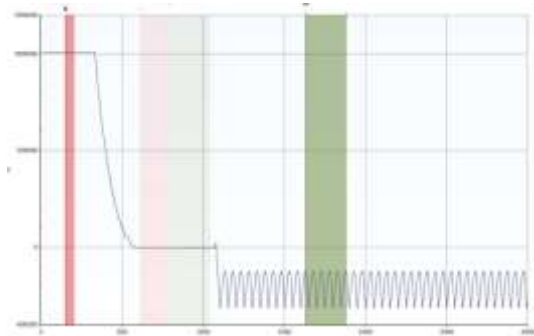

Figure 2 – The wave structure metrology of a Cu diamond turned part using an Alpha step touch probe.

Foam Manufacturing and Characterisation

All foams are produced by reacting a trifunctional acrylic monomer in a non-volatile solvent. After Ultra-violet (UV) curing a gel is formed, the liquid phase is then exchanged with a Carbon Dioxide (CO₂) soluble solvent (methanol). The gel-methanol mixture is transferred to a high-pressure vessel; after exchange with CO₂ the liquid phase is released, and the foam remains intact [5].

Final assembly of these targets involved assembling the foam (still held within the PI tube) directly onto the modulated interface and securing it in place with glue. X-ray radiography was used to check the foam quality and contact with the central structure (Figure 3).

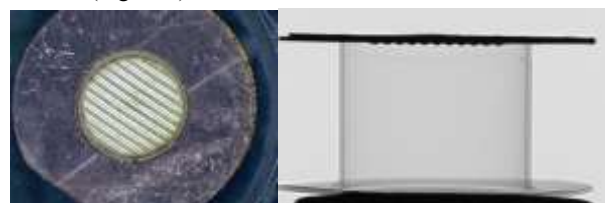

Figure 3 – a) Left - optical image showing how the target looked prior to final foam assembly. b) Right - X-ray radiography of final target to check foam quality and contact.

Challenges & different approaches

Various assembly challenges were encountered during the fabrication of these targets and have been described in an earlier

report [1]. In addition to these assembly challenges the foam/modulated interface contact on several of the targets was unsatisfactory, see Figure 4. A small gap between the mono-mode wave and foam can be seen, as well as shrinkage to the foam on the near side of the PI tube. This is due to a number of factors such as the foam shrinking during the manufacture process, the tube flexing and damaging the foam and also that the foam and tube is assembled to the pusher after it has been manufactured and therefore leaving a non-zero gap between the parts.



Figure 4 – Zoomed in X-ray image showing more clearly the unsatisfactory foam-interface contact.

The first designs for LLE experiments used a target holder that was rectangular in nature to allow the manufacture of the foams (100 mg/cc) directly into holders. To replace the Kapton tubes, 2 x 25um thick PI windows were added to the open sides. The modulated interfaces (both mono- and bi-mode, approximately 130um thick) were then glued to a 25um PI ablator and assembled directly to the top of the clip holder (Figure 5).

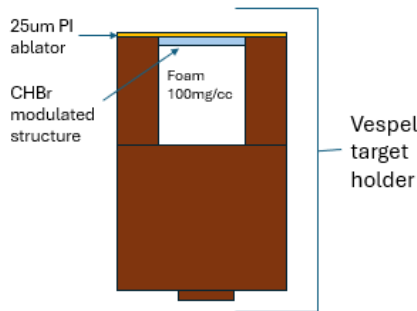

Figure 5 – Basic schematic of the different target design.

Whilst this design is an improvement in many areas the foam - modulation interface still suffers from assembly issues as the foam was not filled and cured in contact with the modulated pusher. An improvement in the contact between the 2 was identified however whilst there was contact between the foam and the peaks of the modulation the foam does not fill inside the valleys as can be seen in the optical image in Figure 6 and the X-ray images in Figure 7.



Figure 6 – Optical image showing a close-up of the foam-interface interaction.

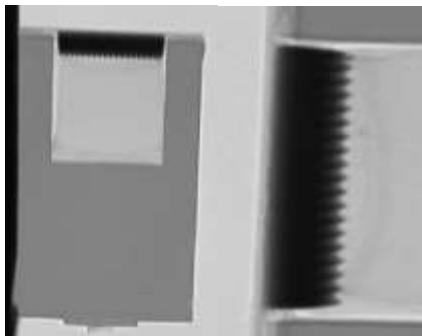

Figure 7 – a) Left - X-ray radiograph checking the foam quality and contact with the modulated interface. b) Right - close-up image showing the poor foam-interface contact.

To improve the foam-interface yield of target, a new clip target was designed by the teams at LLE and the University of Michigan, which enabled the manufacture of the foam directly

onto the modulated structures. To ensure only the best targets were used, a more thorough metrology process was introduced, which included characterisation of parts at every stage of the target assembly.

Integrated Target Design

The integrated target allows for a CHBr flat pusher or mono-mode structure (120um thick) to be assembled into the bottom of a new design holder with a 25um thick PI ablator. A 100mg/cc dense foam can then be manufactured directly onto the interface (Figure 8). Using either a machined VESPEL part provided by Michigan or a printed part with PI windows attached, provided by SPL (Figure 9) the foam solution is added directly onto the modulated pusher before curing. This allows good contact between the two critical components and removes the assembly problems previously seen. The benefit of an integrated target also includes mounting points for diagnostic and shielding components in the machined or printed assembly.

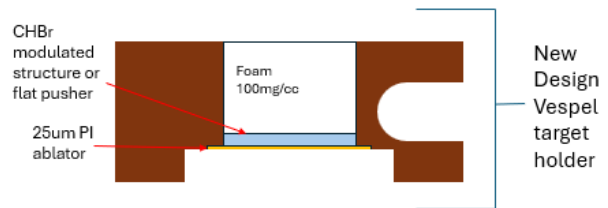

Figure 8 – Basic schematic of new target design.



Figure 9 – Optical images of a 3D printed clip holder. a) Left - without the PI windows. b) Right - with additional assembly of PI windows.

Metrology & Characterisation

Following assembly of the interface/PI ablator to the bottom of the clip holders, optical images of each side were taken to check the structure visually and to ensure there were no breakages during the initial part of assembly as the Brominated parts are very brittle and any cracks would seed instabilities that were not part of the required profile (Figure 10).

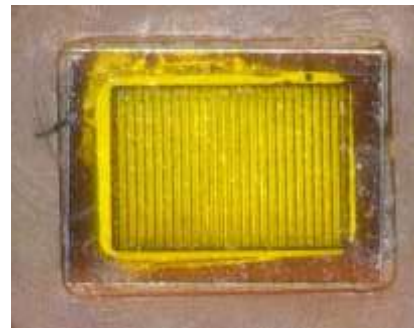

Figure 10 – An optical image of the underside of a mono-mode wave as seen through the PI ablator assembled into bottom of a Vespel clip holder.

White light interferometry scans were used to check the wave profile (Figure 11) and flat surface structure once assembled into the clip holder. This enabled us to be sure the modulated profile or flat foils are parallel to the target assembly and therefore the drive beams. The assembly was also checked for the surface

quality of the interface, and the consistency of glue layer between the underside of the interface and PI ablator to ensure no air/vacuum gaps were present.

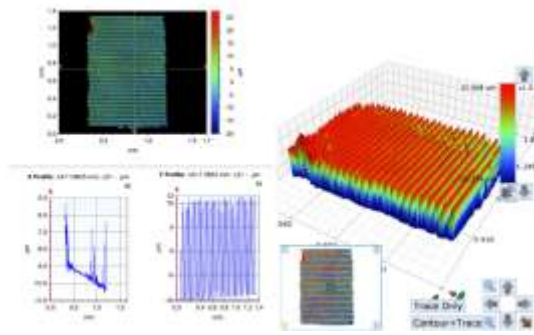

Figure 11 – A white light interferometry scan checking the wave structure once assembled into the clip holder.

After optical images and interferometry scans several targets were identified at this stage as having either an uneven glue layer or damages seen to the interface so were cleaned out and re-assembled with new parts. The parts that passed these inspections then went for foam production.

Low density foams (100 mg/cc) were manufactured directly into the holders. As with previous target designs, a final X-ray radiograph of each target was done to verify the foam quality and contact with the interface (Figure 12). Those that didn't meet requirements were cleaned out and re-assembled or re-filled, as necessary.

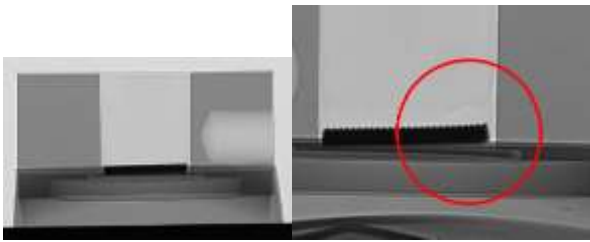

Figure 12 – a) Left - an X-ray radiograph showing a complete target with good foam/mono-mode wave interface contact. b) Right - an X-ray radiograph showing poor foam contact and a slight lift of the interface from the PI ablator.



Figure 13 – Optical images of the complete target as seen from above. a) Left - in a Vespel holder and b) Right - in the 3D printed holder with additional PI windows.

It was found that the numbers of targets rejected at the foam characterisation stage was much lower for the integrated target than for the assembled foam/interface targets. From a fabrication point of view there was limited difference between the solid VESPEL target and a printed mount, with slightly less assembly needed for the VESPEL targets.

B. Jet-Launcher Targets

A second set of targets on a similar platform were then developed for experiments in 2024. Again adjustments to the design were made throughout the year to improve the target performance and these will be discussed. The aim of these experiments was to characterise the formation and the propagation of plasma jets formed by the laser interaction as they move into a low-density

medium such as a foam. As in the previous section the targets are imaged using X-rays generated by a second laser interaction in the chamber.

Initially, the LLE target holder pursued a design much like the VESPEL target holders used for the modulated targets with the shielding and the target package all machined from one piece to ensure that accuracy and repeatability was well controlled. In this case the target was manufactured from an Al piece with the interaction of interest not being a modulated foil but a thin Al foil attached to a raised aluminium cylinder with a jetting cavity machined into it. A 25um thick PI ablator was glued to the underside of the clip, and an Au washer sat around the central raised part (Figure 14).

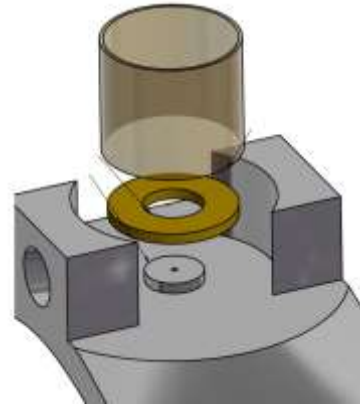

Figure 14 - The Jet launching target design provided by S. Klein (University of Michigan).

To ensure that the radiography could see a clean interaction it was important to minimise and to understand any surface features that would be around the area that the jet would exit the cavity. Therefore, the surface roughness of the raised Al step was measured using white light interferometry and the diameter of the cavity entrance was also checked optically. Upon inspection it was possible to identify the best targets for the campaign and also to understand machining variations between the parts, where tool wear was a big issue. The small drill parts needed would provide good results for the first few targets but as it wore burring was observed, as seen in the Figure 15b below.

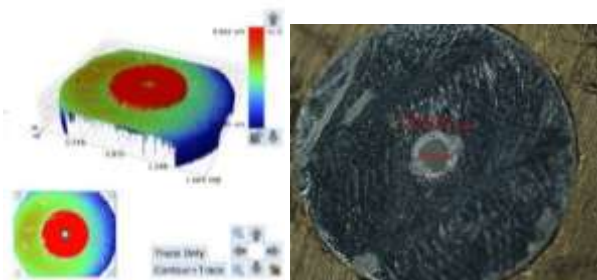

Figure 15 – a) Left - white light interferometry scan showing the surface roughness and level with the Au washer assembled. b) Right – an optical image showing the diameter (and clear burring) of the central cavity of the Al part, after assembly of the Au washer.

Following these checks, low density foams (100mg/cc) were manufactured within PI tubes and then assembled over the Au washer/raised Al part. X-ray radiography was used to check the foam quality and contact with the centre for each target (Figure 16a) and optical images were taken for identification (Figure 16b).



Figure 16 – a) Left - x-ray radiography showing the foam quality of a completed target. b) Right - optical image of the complete target.

The cavity was not visible in the radiograph images when the gold washer was assembled as the absorption of this part was much higher therefore metrology of the cavity was needed before assembly. To achieve this a full 360-degree X-ray CT of one of the parts was completed. This generated very useful inspection data and enabled a detailed analysis at the cavity morphology (Figure 17). However due to the large scan area that was of interest the scan took a considerable amount of time (overnight 12+ hours) so at this stage it was not a viable option if required to scan multiple parts.

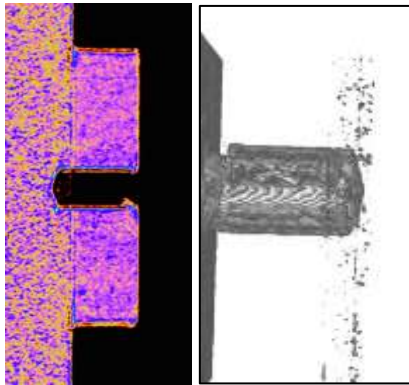

Figure 17 – a) Left - cross-section of a cavity of the Al clip part. b) Right - inverse of the cavity hole.

Target Design Evolution – Acrylic Holder

After this first experimental run of these targets further design changes were implemented. The shielding part of the target which was made from one piece with the jetting part and was made from Al was changed to an acrylic piece. The jetting part of the target, which was still Al was a separate piece that fitted into the Al shield. As before, a 25um PI ablator was glued to the underside, a Au washer was added to sit around the raised jetting area, and a 100mg/cc dense foam was manufactured into a PI tube that was placed over the jetting interaction point (Figure 18). The benefit of having a separate shield and interaction part for this target is that the metrology of the critical parts of the target can be carried out earlier in the process and more suitable targets can be prioritised during production.

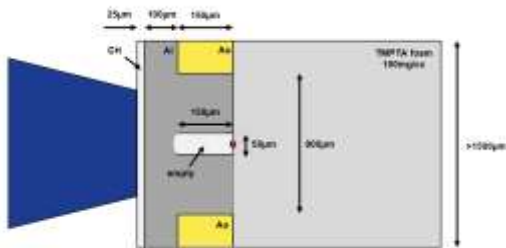

Figure 18 – Schematic of the aluminium and foam part that was manufactured separately from the acrylic holder.

As before the surface roughness of the jetting target was measured using a white light interferometry scan, and optical images taken to check the cavity diameter. It was noted that the change of production technique let to some unexpected features

and machining marks on the jetting part of the target and again it was noted that to improve the surfaces tool wear was an issue and targets made later in batches (Figure 19) showed significantly more burring than early targets (Figure 20).

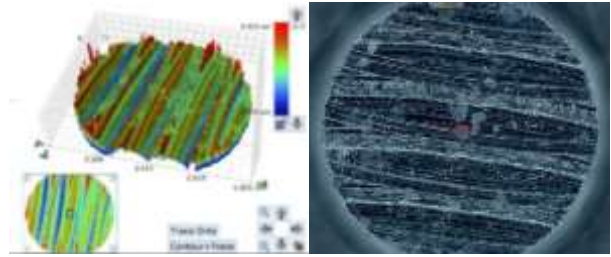

Figure 19 – a) Left - white light interferometry scan showing the very rough surface of the Al part. b) Right - optical image showing the diameter of the cavity and the poor surface quality.



Figure 20 – Optical image of good quality Al part taken to measure cavity diameter, and to check for artifacts around the cavity.

Change of Cavity Design

For this iteration of design there were three cavity types (conical, small, and large) that were used. These were characterised using X-ray CT and as the parts were smaller it was possible to reduce the scanning window, the resolution and also the number of rotation steps and still be able to achieve a good reconstruction of the data. This therefore reduces the scan time for the parts (30 mins) and made it possible to scan every cavity that was to be used on the experiment. The data from these scans still provided sufficient cross-sections of the cavities showing the morphology and depth (Figures 21 and 22).

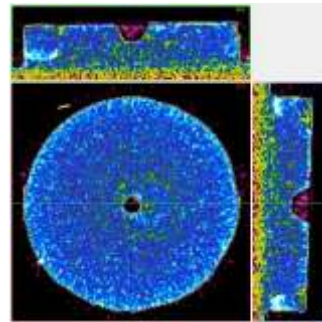

Figure 21 – Example 360-degree X-ray radiography of a conical cavity type within an Al part.

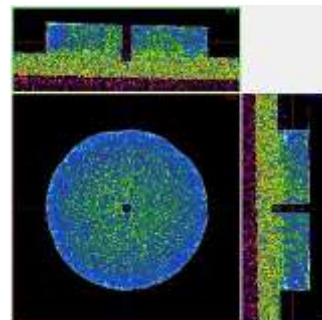

Figure 22 – Example 360-degree X-ray radiography of a straight cavity type within an Al part.

As before, the manufacture of the 100mg/cc foam was within PI tubes. The foam quality was checked, to ensure good foam – jet launching cavity contact, using X-ray radiography prior to final assembly, and a final radiograph of each complete target was carried out (Figure 23a). The final target can be seen in Figure 23b.



Figure 23 – a) Left - X-ray radiography of complete target. b) Right - optical image of the complete target.

Future Developments – Single Point Diamond Turning

The most critical part of the jet launching targets is the surface quality around the jetting area. To ensure clean imaging of the jet no features that could cause instabilities should be present. Standard CNC machining can give good surface finish to around a few microns but to achieve the highest quality surfaces it is preferable to use single point diamond turning. To develop the platform further for the future SPL post processed a target to skim the surface around the jetting hole. Using a Precitech Nanoform X lathe we were able to show significant improvements in surface roughness that were shown optically (Figure 24) and also by scanning using a white light interferometer (Figures 25 and 26). Whilst these are yet to be experimentally tested this shows a route to achieving the highest quality surfaces on these targets reducing some of the inconsistencies and unknowns when taking data shots.



Figure 24 – An optical image of the diamond turned surface around the cavity. The black is a highly reflective surface that is not scattering the light from the microscope.

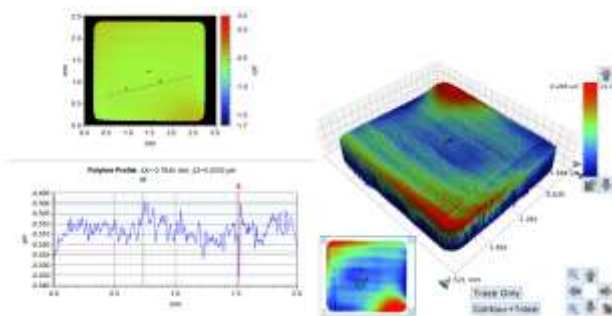

Figure 25 – White light interferometry of the surface of the jet launching package. Surface roughness over the whole part is approximately +/- 15nm.

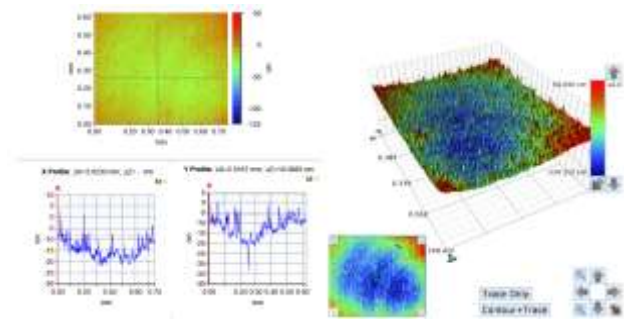

Figure 26 – White light interferometry of a sub-section surface of the jet launching package. Surface roughness over a smaller area is approximately +/-10nm.

Conclusion

A collaboration between LLE, the University of Michigan and Scitech Precision Ltd has carried out a range of experiments where the target platforms have been improved by the introduction of high-quality micromachining, high resolution 3D printing and thorough characterisation during the manufacture process. This has been compared to experimental performance and optimised version of the target have been carried forward to the next campaigns. In addition, future improvements have been identified using single point diamond turning to post process targets to improve surface finish to ensure high quality data can be taken.

Acknowledgements

This material is based upon work supported by the Department of Energy [National Nuclear Security Administration] University of Rochester “National Inertial Confinement Fusion Program” under Award Number(s) DE-NA0004144.

References

- [1] - Laboratory for Laser Energetics
- [2] – C. Dobson et al., Using Additive Manufacturing to Aid the Fabrication of Complex 3D Micro targets. *CLF Annual Report 2022-2023*.
- [3] - Rigon, G., Albertazzi, B., Pikuz, T. *et al.* Micron-scale phenomena observed in a turbulent laser-produced plasma. *Nat Commun* **12**, 2679 (2021). <https://doi.org/10.1038/s41467-021-22891-w>
- [4] – P. Ariyathilaka, Development of low-density sine wave targets for high power laser experiments. *CLF Annual Report 2019-2020*.
- [5] – S. Irving et al, Embedding of Ruby Microspheres in Low Density Foam Targets. *CLF Annual Report 2022-2023*.